

L.065AL / L.065GL / L.065STS < Blade types

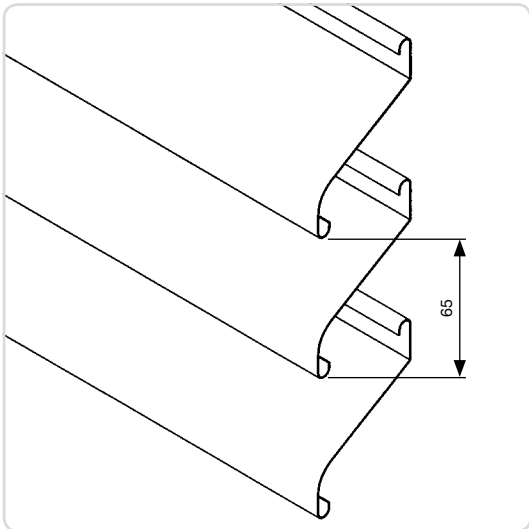

Rolled blades

Rolled aluminium profile (L.065AL); rolled aluminium profile, perforated (L.065AL .02) galvanized steel (L.065GL) or stainless steel (L.065StS). Light duty strip material with a pitch of 65 mm and resistance to normal weather conditions. For use as a screen, ideal if a low-priced solution is required. Mounted with a soft flowing appearance (M1) or with front corner line (M2).

Materials

- Aluminium EN AW 3005-H18
- Galvanised steel EN 10142
- Stainless steel

Finish

Polyester powder coating RAL or Syntha Pulvin® colours (60 - 80 µ/40 µ (UK)) - (only for L.065AL)

Mesh

Fixed to rear of the support structure.

Doors

Only with L.065AL

Blade support

- Type L.065AL:
 - Single blade support type L.065AL.11 (width: 28 mm)
 - Double blade support type L.065AL.12 (width: 45 mm) (connecting piece for 2 blades)
- Type L.065GL & StS:
 - Single blade support type L.065GL.11 (width: 28 mm)
 - Double blade support type L.065GL.12 (width: 45 mm) (connecting piece for 2 blades)

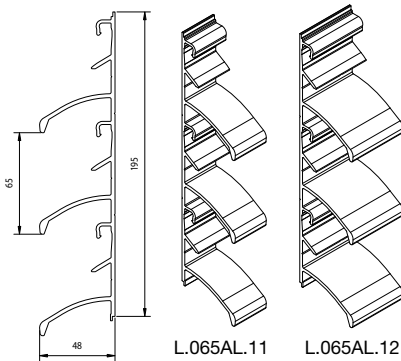
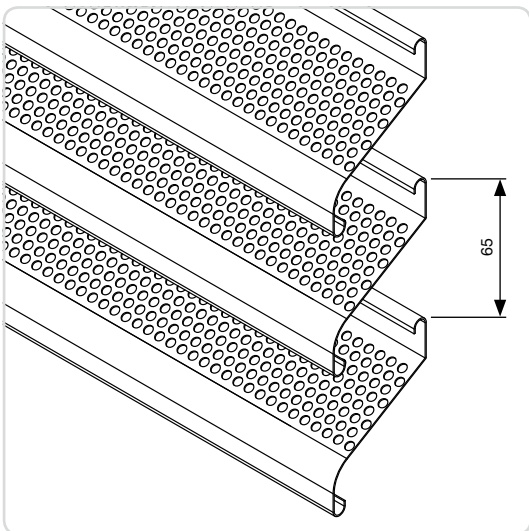

L.065AL

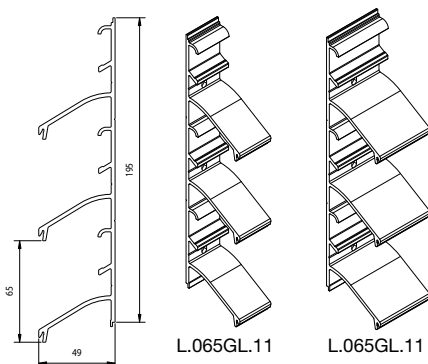

L.065GL

Technical drawings

Type L.065: 2 fastening options

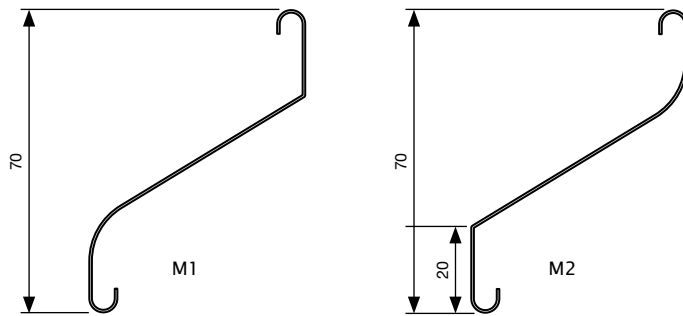

Technical data

	L.065AL, GL & STS
Pitch	65 mm
Depth	50,0 mm
Height	70,0 mm
K-Factor*, supply	13,32
Visual free area*	70%
Physical free area*	56%
Max. unsupported span between two mullions**	1200 mm

* Definition see p. 50

** At q_b 800 Pa wind pressure

