

## L.050CL < Blade types

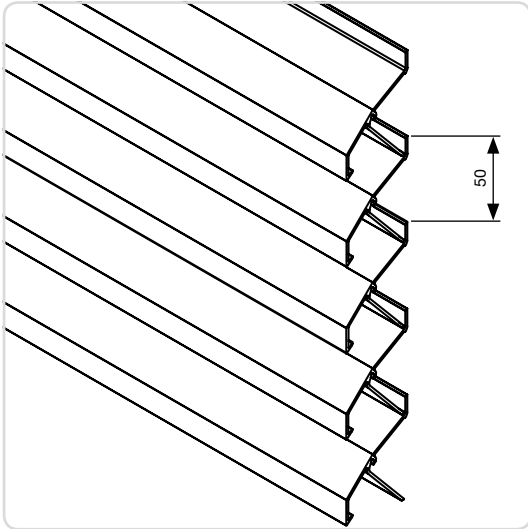

L.050CL



### Extruded aluminium blade

#### Applications

Often used in cases where the step between the blades display the aesthetics of the project design. Available as doors, shapes and circles.  
L.050CL - Suitable for fully or partially closed continuous louvre systems.

#### Materials

Aluminium extrusion, alloy EN AW 6063 T66

#### Finish

- Anodised (20 micron)
- Polyester powder coating RAL or Syntha Pulvin® colours (60 - 80 µ/40 µ (UK))

#### Doors

Single and double doors available with standard RENSON® hardware and rotating on pivot (see p. 71-72).

#### Blade support

- Single blade support: type L.050.110 (width: 28 mm)
- Double blade support for thermal expansion: L.050.120 (width: 34 mm) (connecting piece for 2 blades)

#### Technical drawing

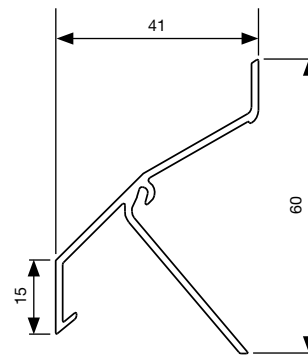

#### Technical data

	L.050CL
Pitch	50 mm
Depth x Height	41 x 60
Max. unsupported span between two mullions**	2100 mm
* Definition see p. 50	
** At qb 800 Pa wind pressure	